

PITBULL

GROUND CONVEYOR

An adjustable static material moving conveyor allowing height adjustment for varying project requirements.

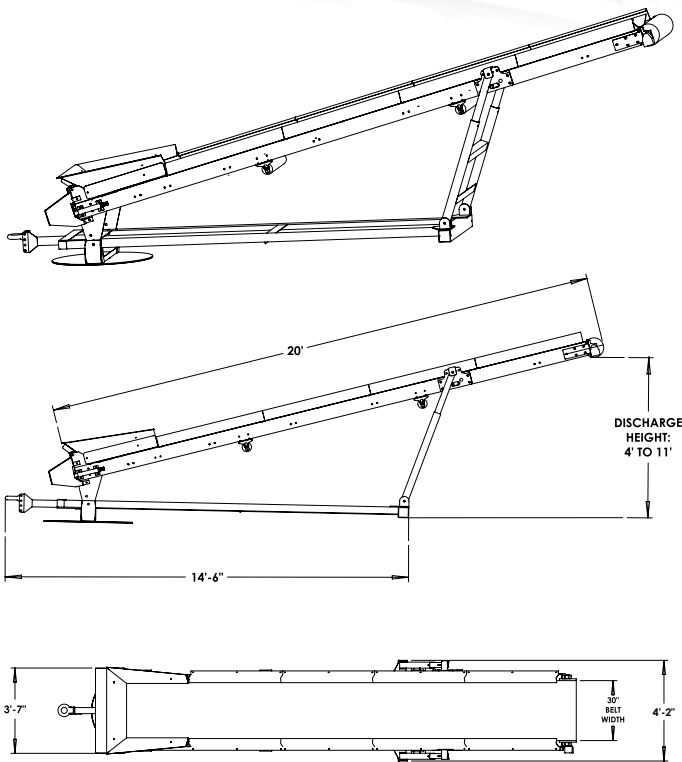

The Pitbull Ground Conveyor is adjustable to meet your project's height requirements.

The Pitbull Ground Conveyor is designed to be static and requires equipment to move the unit. As with all Pitbull conveyors, it shares the rugged welded Pitbull frame and the robust head and tail pulleys to assist in smooth operation for optimal production.

The Pitbull Ground Conveyor is designed to work in conjunction with the 2300 series of screeners. The ground conveyor may work alone or in harmony with the Pitbull radial stacker to configure a two or three way split system.

Request a quote or demo today!



PITBULL

GROUND CONVEYOR

4" diameter
CEMA "B" bed
rollers with
sealed bearings



Standard with
20' (long) x
30" (wide) smooth
vulcanized belts



9" lagged head pulley
and 9" herringbone
tail pulley

Features

- Strong "C" channel conveyor frame utilizing full length torque tube reinforcements
- Carrier frame is rugged structural tube steel fully welded and reinforced for durability and long dependable service life
- Standard with hydraulic drive on head pulley
- Standard with 20' (long) x 30" (wide) smooth vulcanized belts
- Tip height manually adjustable
- Greaseable pillow block bearing on both head and tail pulley shaft
- Requires additional equipment for transport or repositioning
- Economical to own with minimal maintenance

Specifications

Conveyor Bed

4" CEMA B 20-degree uneven troughing rollers form tough conveyor belt bed

Belt Size

20' long, 30" wide

Pulleys

9" lagged head pulley and 9" herringbone tail pulley run on 1-15/16" shafts

Standard with

Hydraulic torque motors.
Adjustable stack height.

Optional

Gas or diesel self-contained power units
Electric motor drive in head pulley

Request a quote or demo today!

